

SECTION A-A

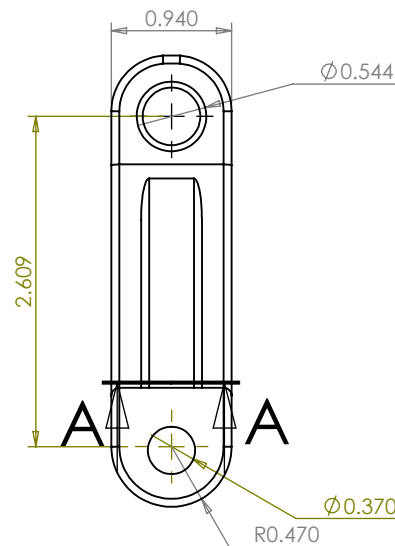
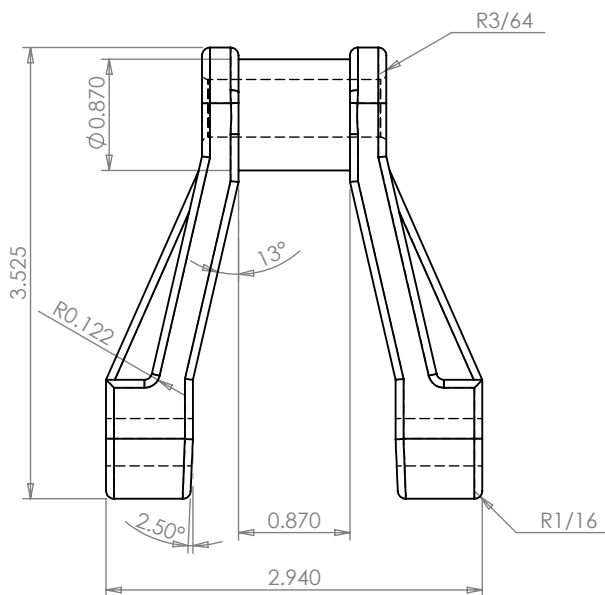

DIMENSIONS ARE IN INCHES
 TOLERANCES:
 FRACTIONAL $\pm 1/64$
 ANGULAR: $\pm 0^\circ 30'$
 TWO PLACE DECIMAL ± 0.010
 THREE PLACE DECIMAL ± 0.005

PLASTOCK®
 Manufactured by Putnam Precision Molding

Part Number:
26-D

www.plastock.biz
 © 2010 Putnam Precision Molding

Part Description:
 Drag/Pintel Series

PROPRIETARY AND CONFIDENTIAL : THE INFORMATION CONTAINED IN THIS DRAWING IS THE SOLE PROPERTY OF PUTNAM PRECISION MOLDING. ANY REPRODUCTION IN PART OR AS A WHOLE WITHOUT THE WRITTEN PERMISSION OF PUTNAM PRECISION MOLDING IS PROHIBITED. INFORMATION IN THIS DRAWING IS PROVIDED FOR REFERENCE ONLY.